

PQ PROTECTION SURGE PROTECTION DEVICES PQC320 & PQCF320 SERIES



PQC(F)320 is a high-performance, robust, surge protective device (SPD) with advanced features, protecting your facility's electrical equipment from damaging electrical power surges due to lightning; utility power generation/distribution systems; and inductive load switching equipment within your facility. Intended for service entrances, distribution panels, MCCs, branch panels, lighting panels, and large equipment applications (e.g., HVAC).

The PQC(F)320 is automatic in operation, resetting after activation to provide continuous protection of electrical equipment. The Ground Reference feature indicates if potential between neutral and ground exceeds ~20 V. PQC(F)160 SPDs feature pre-wired remote monitoring contacts.

The PQC320 standard series is UL Type 1 listed (automatically suitable for UL Type 2) and can be installed before or after the service equipment overcurrent device, with or without a dedicated circuit breaker for the SPD.

The PQCF320 with EMI Filter option is UL Type 2 listed and can be installed after the service equipment overcurrent device. The PQCF320 EMI Filter series protects your facility equipment from internally generated transients such as oscillatory ring waveforms – typically due to switch-mode power supplies (most modern electronic equipment).

ISO 9001:2014 Quality Management System, ISO 17025:2007 Laboratory Certification (UL DAP Program), and 100% Quality Tested prior to shipping.



PRODUCT SPECIFICATIONS	
Status Indication	Individual LED indicators Mode per Line/Phase, and Alarm; Audible Alarm, and Ground Reference Indication
Certifications	UL® 1449 Edition 5 Type 1 / Type 2, 20 kA I _n UL® 1449 Edition 5 Type 2, 20 kA I _n , UL® 1283 Edition 7 (EMI Filter Models)
Complies With	UL® 96A and NEC® Article 242 (Article 285 - prior to 2020) ANSI®/IEEE® C62.41.1-2002 Cat A, Cat B, Cat C ANSI®/IEEE® C62.41.2-2002 Cat A, Cat B, Cat C ANSI®/IEEE® C62.45-2002 Cat A, Cat B, Cat C MIL-STD-220A (EMI Filter Models)
Short Circuit Current Rating (SCCR)	200 kA
Maximum Discharge Current (I_{max})	320 kA per phase / 160 kA per mode - 8/20 μs
Nominal Discharge Current (I_n)	20 kA
Frequency	50 Hz, 60 Hz, 400 Hz
Filtering (EMI Filter Models)	-39.7 dB @ 100 kHz
Operating Temperature	-40° to 185°F (-40 to 85°C)
Mounting	¾" nipple mount, optional Flush Mount kit
Enclosure Rating	NEMA® Type 4X, UL® 50E Type 4, suitable for indoor or outdoor installation
Enclosure Material	Polycarbonate
Depth	3 in.
Width	6.9 in. w/o nipple
Height	6.9 in.
Weight	4 lb.
Recommended Circuit Breaker	20A or 30A, multi-pole as required
Connections - Conductor Size	10 AWG stranded, ~36" length
Remote Monitoring - Contacts	Form C, 2 A @ 240 V, 22 AWG stranded, ~36" length, IoT, BMS, and SCADA compatible
Warranty	Ten (10) Years

PQ PROTECTION SURGE PROTECTION DEVICES PQC320 & PQCF320 SERIES



STANDARD MODELS PQC320(-S)		MCOV	VPR			
Model Number	Configuration	(V)	L-G (V)	L-N (V)	N-G (V)	L-L (V)
PQC320-120V-1P	120V, Single-phase, 2W+G	180	800	700	600	-
PQC320-240V-1P	240V, Single-phase, 2W+G	350	1200	1200	1000	-
PQC320-120/240V-SP	120/240V, Split-phase, 3W+G	180/360	800	700	600	1200
PQC320-120/208V-3Y	120/208V, 3-phase Wye, 4W+G	150/300	700	600	600	1000
PQC320-277/480V-3Y	277/480V, 3-phase Wye, 4W+G	350/700	1200	1200	1000	2000
PQC320-347/600V-3Y	347/600V, 3-phase Wye, 4W+G	440/880	1500	1500	1500	2500
PQC320-240V-3D	240V, 3-phase Delta, 3W+G	275	900	-	-	1200
PQC320-480V-3D	480V, 3-phase Delta, 3W+G	550	1800	-	-	1800
PQC320-120/240V-HLD	120/240V, High-leg Delta, 4W+G	180/275	800/900	800/1000	700	1200/1500

To add optional Surge Counter - insert "-S" in model number, e.g., "PQC320-S-120V-1P"

EMI FILTER MODELS PQCF320-S		MCOV	VPR			
Model Number	Configuration	(V)	L-G (V)	L-N (V)	N-G (V)	L-L (V)
PQCF320-S-120V-1P	120V, Single-phase, 2W+G	180	800	700	600	-
PQCF320-S-240V-1P	240V, Single-phase, 2W+G	350	1200	1200	1000	-
PQCF320-S-120/240V-SP	120/240V, Split-phase, 3W+G	180/360	800	700	600	1200
PQCF320-S-120/208V-3Y	120/208V, 3-phase Wye, 4W+G	150/300	700	600	600	1000
PQCF320-S-277/480V-3Y	277/480V, 3-phase Wye, 4W+G	350/700	1200	1200	1000	2000
PQCF320-S-347/600V-3Y	347/600V, 3-phase Wye, 4W+G	440/880	1500	1500	1500	2500
PQCF320-S-240V-3D	240V, 3-phase Delta, 3W+G	275	900	-	-	1200
PQCF320-S-480V-3D	480V, 3-phase Delta, 3W+G	550	1800	-	-	1800
PQCF320-S-120/240V-HLD	120/240V, High-leg Delta, 4W+G	180/275	800/900	800/1000	700	1200/1500

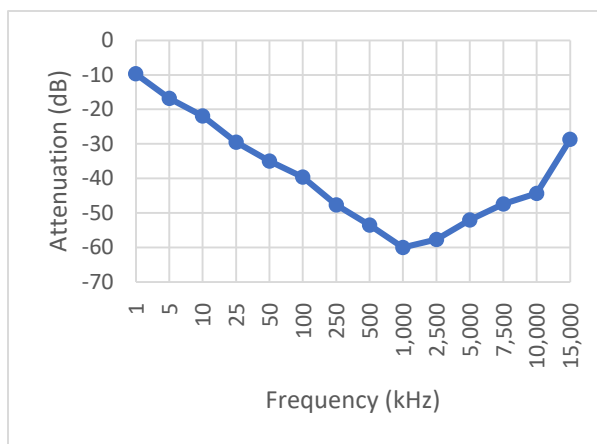

The EMI Filter option mitigates oscillatory ring waveforms – generally caused by non-linear loads inside the facility.

Typical oscillatory ring waveform sources include “transformer-less” switching power supplies for computers, IT equipment (network, monitors, printers), TVs, electronic ballasts for lighting, UPS, Inverter, Rectifier systems and Variable Frequency (speed) Drives.

Flush Mount Kit PQC320-FP
8 in. x 12 in.

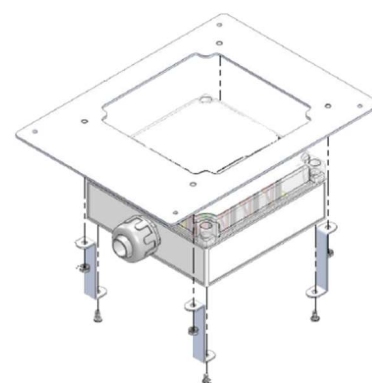

CONFIGURATIONS (Conceptual - refer to IOM for installation instructions)

